

M-SERIES

SUBMITTAL DATA: MSZ-GL12NA-U1 & MUZ-GL12NA-U1

12,000 BTU/H WALL-MOUNTED HEAT PUMP SYSTEM



Job Name: _____

System Reference: _____ Date: _____



ACCESSORIES:

Indoor Unit

- Condensate Pump (BlueDiamond X87-711/721; 115/230V)
- Condensate Pump (Sauermann SI30-115/230; 115/230V)
- Anti-Allergy Enzyme Filter (MAC-408FT-E)
- Drain Pan Level Sensor (DPLS2)

Outdoor Unit

- Outdoor Mounting Pad (ULTRILITE1)
- Drain Pan Heater (MAC-840BH-U)
- 3-1/4" Mounting Base [Pair] (DSD-400P)
- Drain Pan Socket (MAC-860DS)
- Air Outlet Guide (MAC-889SG)
- Wall Mounting Bracket (QSWB2000M-1)

Controls

- Wireless Controller (MHK1)
- Wired Remote Controller PAR-31MAA (Requires MAC-333IF-E)
- Wireless Interface for kumo cloud™ (PAC-WHS01WF-E)
- Thermostat Interface (PAC-US444CN-1)

SPECIFICATIONS:

Rated Conditions (Capacity / Input)		
Cooling ¹	Btu/h / W	12,000 / 920
Heating at 47° F ²	Btu/h / W	14,400 / 1,100

Capacity Range		Minimum	Maximum
Cooling ¹	Btu/h	1,500	13,600
Heating at 47° F ²	Btu/h	2,000	18,100
Heating at 17° F ³	Btu/h	-	12,000
Heating at 5° F ⁴	Btu/h	-	9,700

¹ Cooling | Indoor: 80° F(27° C)DB / 67° F(19° C)WB; Outdoor: 95° F(35° C)DB / 75° F(24° C)WB*
² Heating at 47° F | Indoor: 70° F(21° C)DB / 60° F(16° C)WB; Outdoor: 47° F(8° C)DB / 43° F(6° C)WB*
³ Heating at 17° F | Indoor: 70° F(21° C)DB / 60° F(16° C)WB; Outdoor: 17° F(-8° C)DB / 15° F(-9° C)WB*
⁴ Heating at 5° F | Indoor: 70° F(21° C)DB / 60° F(16° C)WB; Outdoor: 5° F(-15° C)DB / 5° F(-15° C)WB*
 * Rating Conditions per AHRI Standard:

Operating Conditions (Indoor Intake Air Temp.) (Max./ Min.)	
Cooling ²	90° F (32° C) DB / 67° F (19° C) DB
Heating	80° F (27° C) DB / 70° F (21° C) DB

Operating Conditions (Outdoor Intake Air Temp.) (Max./ Min.)	
Cooling ⁵	115 F (46° C) DB / 14° F (-10° C) DB
Heating	75° F (24° C) DB / -4° F (-20° C) DB**

⁵ Applications should be restricted to comfort cooling only; equipment cooling applications are not recommended for low ambient temperature conditions.
 ** System cuts out at -9° F (-27° C) to avoid thermistor error and automatically restarts at -4° F (-20° C).

AHRI Efficiency Ratings	
SEER / HSPF	23.1 / 12.5
COP at 47° F / 17° F	3.84 / 3.1

Energy Star®	Yes
--------------	-----

ENERGY STAR products are third-party certified by an EPA-recognized Certification Body.

Specifications are subject to change without notice.

Electrical Power Requirements	208 / 230V, 1-Phase, 60 Hz
-------------------------------	----------------------------

Minimum Circuit Ampacity (MCA)		
Indoor / Outdoor	A	1 / 9

Indoor Unit		
Blower Motor (ECM)	F.L.A.	0.76
Blower Motor Output	W	30
SHF / Moisture Removal		0.740 / 2.5 pt./h
Field Drainpipe Size O.D.	In.(mm)	5/8 (15)

Outdoor Unit		
Compressor		DC INVERTER-driven Twin Rotary
Fan Motor (ECM)	F.L.A.	0.5

Airflow Rate (Quiet - Lo - Med - Hi - Super Hi)			
Indoor (Cooling)	DRY	CFM	145-170-237-321-399
	WET		109-134-201-286-364
Indoor (Heating)	DRY		145-170-237-321-406
			1,229 / 1,172

Sound Pressure Level (Quiet - Lo - Med - Hi - Super Hi)			
Indoor	Cooling	dB(A)	19-22-30-37-45
	Heating		19-22-30-37-43
Outdoor	Cooling		49
	Heating		51

External Dimensions		
Indoor (H x W x D)	In.(mm)	11-5/8 x 31-7/16 x 9-1/8 (295 x 798 x 232)
Outdoor (H x W x D)		21-5/8 x 31-1/2 x 11-1/4 (550 x 800 x 285)

Net Weight		
Indoor	Lbs.(kg)	22 (10)
Outdoor		81 (37)

External Finish	
Indoor	Munsell 1.0Y 9.2 / 0.2
Outdoor	Munsell No. 3Y 7.8 / 1.1

Refrigerant	R410A; 2 lb. 9 oz.
-------------	--------------------

Refrigerant Piping (Flared)		
Liquid (High Pressure)	In.(mm)	1/4 (6.35)
Gas (Low Pressure)		3/8 (9.52)
Max. Total Refrigerant Pipe Length (Height Diff.)	Ft. (m)	40 (12)
Max. Total Refrigerant Pipe Length (Length.)		65 (20)

DIMENSIONS: MSZ-GL12NA-U1 & MUZ-GL12NA-U1

MSZ-GL12NA-U1

Unit: in. (mm)

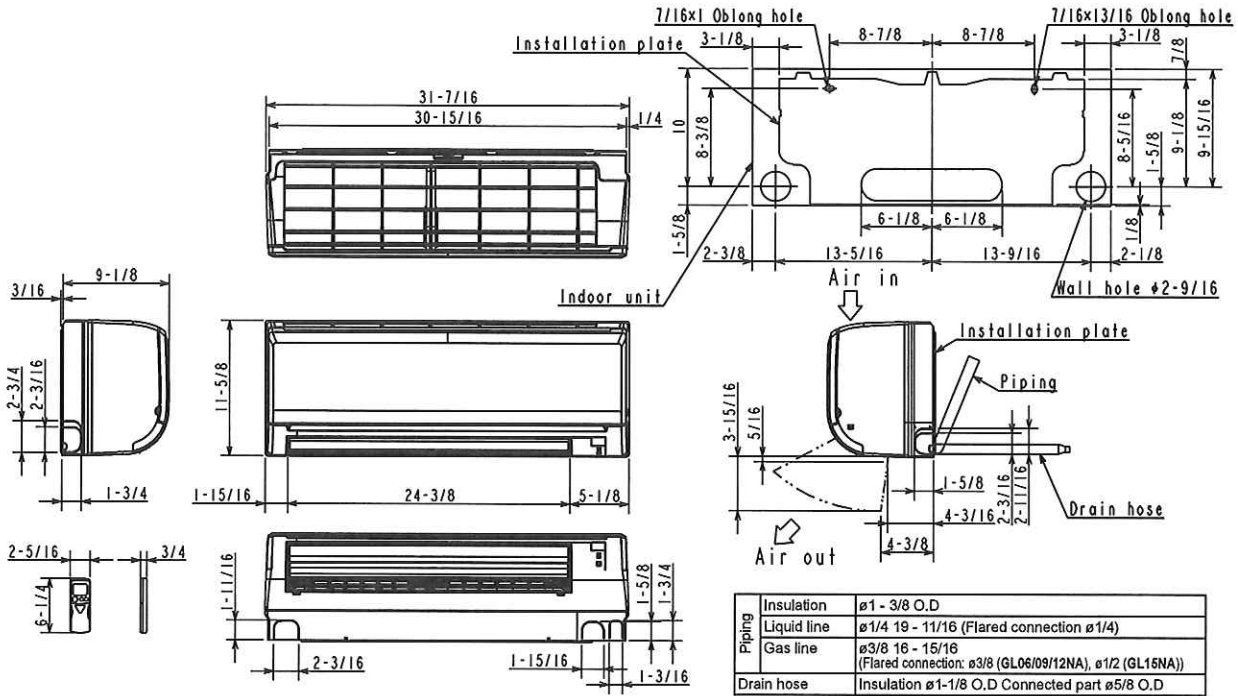

MUZ-GL12NA-U1

REQUIRED SPACE

Unit: in. (mm)

*1 4 in. (100 mm) or more when front and sides of the unit are clear

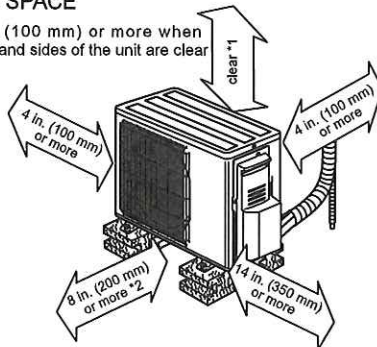

*2 When any 2 sides of left, right and rear of the unit are clear

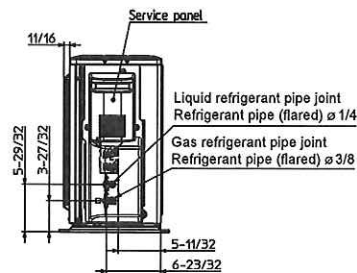
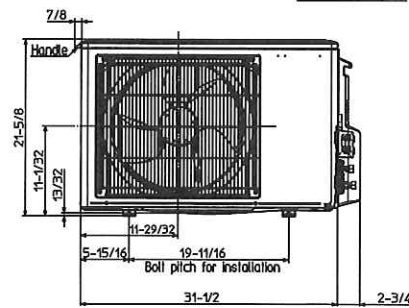
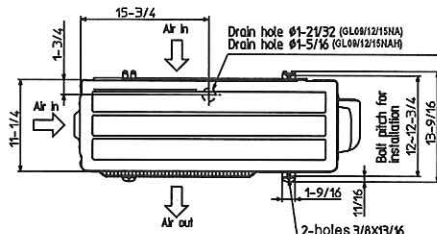

1340 Satellite Boulevard, Suwanee, GA 30024
Toll Free: 800-433-4822 www.mehvac.com

